

PRODUCT DIMENSIONS

ProcessDefender product dimensions are as follows:

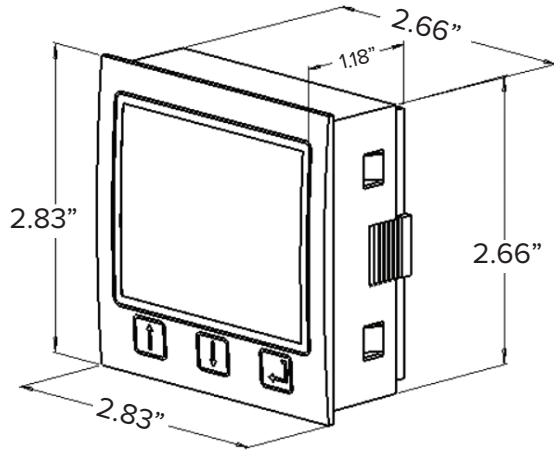

English measurements

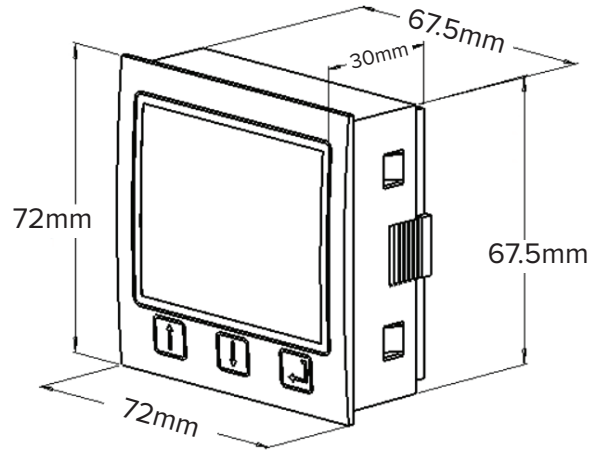

Metric measurements

CUTTING TEMPLATE

Recommended procedure for panel mounting:

1. Cut out the template to the right leaving plenty of white space around the edge of the dotted line
2. Using masking tape in each corner, apply the template to the desired location on the panel door. Use a Level to ensure the template is correctly aligned.
3. Drill holes in each corner of the template large enough for a jigsaw blade.
4. Using a jigsaw, cut along the lines of the template. Be very careful to not extend outside of the dotted line, as there is a relatively small tolerance between the bezel size and the cutout.
5. Lightly use a straight-edge file to remove any burrs and smooth any uneven edges.
6. Install ProcessDefender

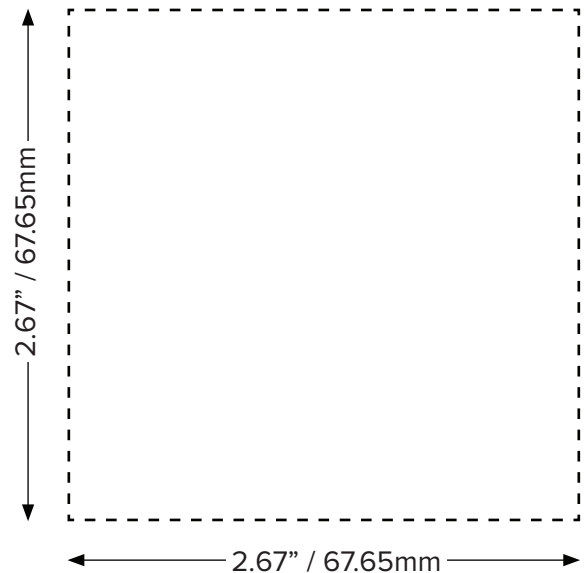

H2flow Controls, Inc.

Tel: (+1) 888.635.0296 | Fax: (+1) 419.517.9900
sales@h2flow.net | www.h2flow.net